

Slam Latch

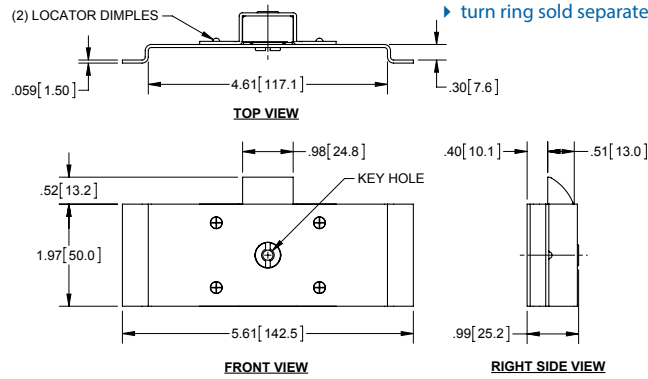
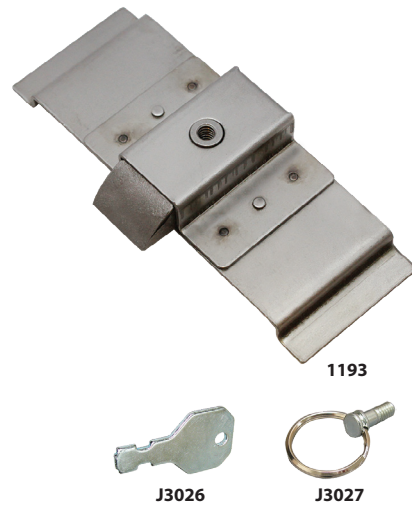

Part Number	Material	Finish
1193	steel housing powder metal bolt	mill

- ▶ key sold separately (part no. J3026)
- ▶ turn ring sold separately (part no. J3027)

Cab Latches

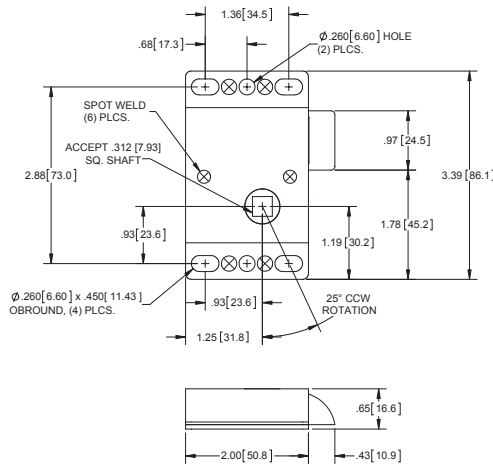
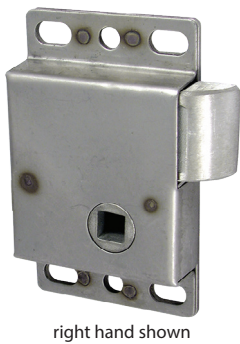

Part Number	Description	Material	Finish
315RSS	right hand	304SS	mill
315LSS	left hand	304SS	mill

- ▶ cast stainless steel bolt
- ▶ accepts .313" sq. shafts
- ▶ right hand latch requires handle with clockwise rotation
- ▶ left hand latch requires handle with counter clockwise rotation

Cab Latches

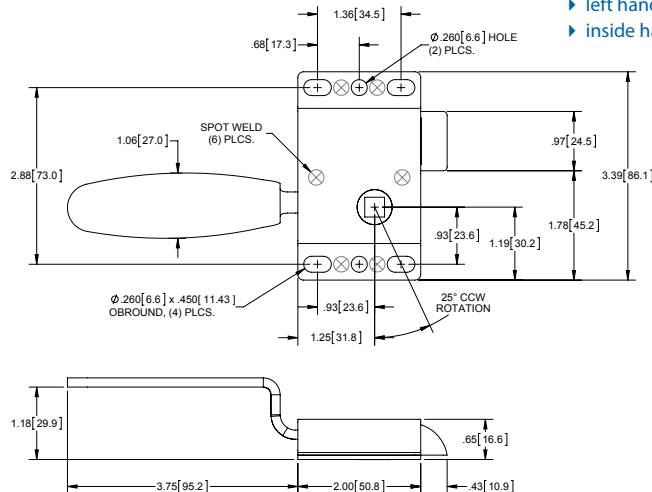
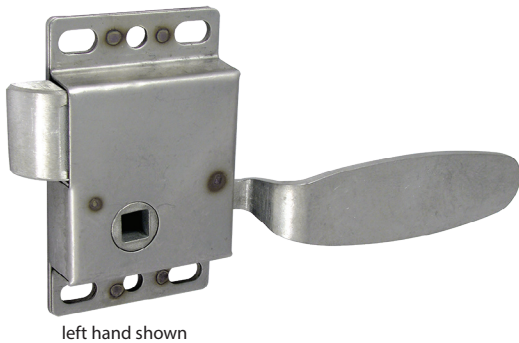

Part Number	Description	Material	Finish
315RSS-01	right hand	304SS	mill
315LSS-01	left hand	304SS	mill
315RZN-01	right hand	steel	zinc plated
315LZN-01	left hand	steel	zinc plated

- ▶ cast stainless steel bolt
- ▶ accepts .313" sq. shafts
- ▶ right hand latch requires handle with clockwise rotation
- ▶ left hand latch requires handle with counter clockwise rotation
- ▶ inside handle will not override outside handle when locked