

## Small Stainless Steel Slam Latches

### Small Slam Latches

Part Number	Material	Finish
123SS	cast 304SS	brushed
123SSP	cast 304SS	hand polished

▶ all components are 304SS

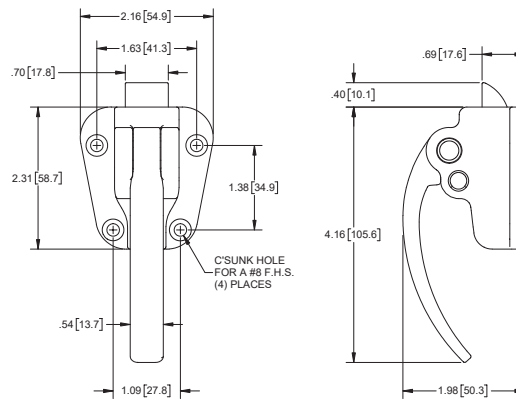
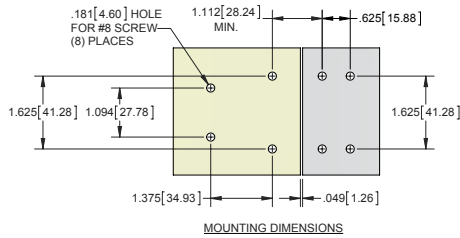

### Small Keepers

Part Number	Description	Grip	Height	Material	Finish
123SS-K1	short keeper	flush to .50 [12.7]	1.78 [45.1]	cast 304SS	brushed
123SSP-K1	short keeper	flush to .50 [12.7]	1.78 [45.1]		hand polished
123SS-K2	tall keeper	.56 [14.3] to 1.25 [31.8]	2.32 [58.9]		brushed
123SSP-K2	tall keeper	.56 [14.3] to 1.25 [31.8]	2.32 [58.9]		hand polished

▶ all components are 304SS

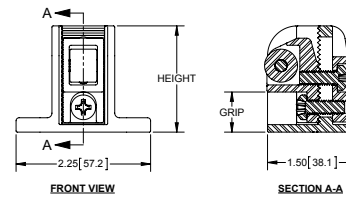
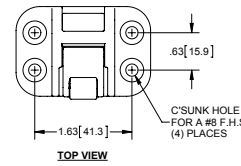

### Large Slam Latch

Part Number	Material	Finish
122SS	cast 304SS	brushed
122SSP	cast 304SS	hand polished

▶ all components are 304SS

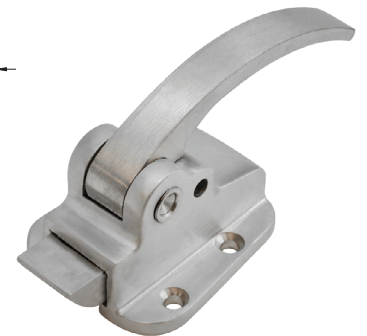
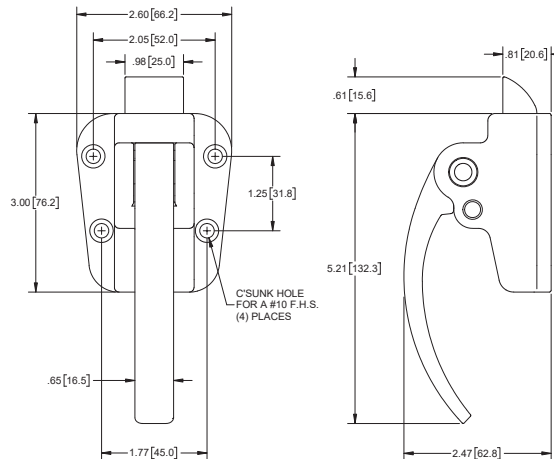
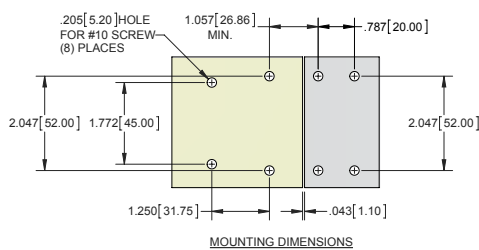

### Large Keepers

Part Number	Description	Grip	Height	Material	Finish
122SS-K1	short keeper	flush to .38 [9.6]	1.78 [45.1]	cast 304SS	brushed
122SSP-K1	short keeper	flush to .38 [9.6]	1.78 [45.1]		hand polished
122SS-K2	tall keeper	.50 [12.7] to 1.25 [31.8]	2.32 [58.9]		brushed
122SSP-K2	tall keeper	.50 [12.7] to 1.25 [31.8]	2.32 [58.9]		hand polished

▶ all components are 304SS

