

Quarter-turn Thumb Latches

316SS NEMA 4 NEMA 4x NEMA 12 IP65 RATED



Part Number	Housing		Thumb-turn Plug		Key Code
	Material	Finish	Material	Finish	
41-30	die cast zinc	bright chrome	die cast zinc	bright chrome	non-locking
41-30BK	die cast zinc	textured black powder coated	die cast zinc	textured black powder coated	non-locking
41-30LK	die cast zinc	bright chrome	die cast zinc	bright chrome	333
41-30BKLLK	die cast zinc	textured black powder coated	die cast zinc	textured black powder coated	333
41-30BKLLK751					CH751
41-30SST	316SS	brushed	316SS	brushed	non-locking

▶ assembly includes: body nut, cam retaining screw, internal O-ring, face gasket, and (2) ringed keys for locking latch

▶ cams sold separately. See pg. 128 for cams & grip dimension

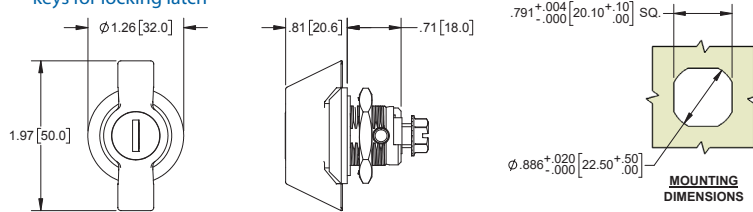

Padlocking Quarter-turn Wing Knob Latches

NEMA 4 NEMA 12 IP65 RATED



Part Number	Housing		Wing Knob	
	Material	Finish	Material	Finish
41-35	die cast zinc	mill	die cast zinc	chrome plated
41-35BK	die cast zinc	mill	die cast zinc	textured black powder coated

▶ assembly includes: body nut, cam retaining screw, internal O-ring, & face gasket

▶ cams sold separately. See pg. 128 for cams & grip dimension

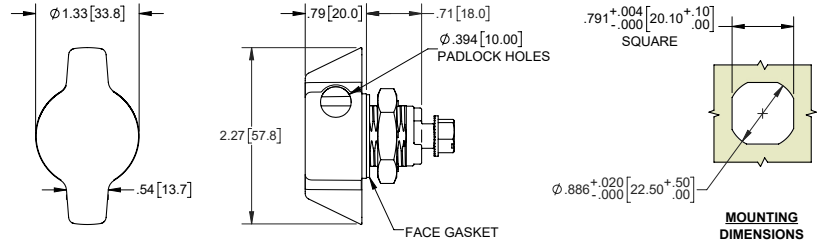

Quarter-turn Thumb Latches

NEMA 4 NEMA 12 IP65 RATED



Part Number	Housing		Thumb-turn Plug	
	Material	Finish	Material	Finish
41-19BK	die cast zinc	black powder coat	die cast zinc	black powder coat
41-19CH	die cast zinc	chrome plated	die cast zinc	chrome plated

▶ assembly includes: body nut, cam retaining screw, internal compression spring, internal O-ring and face gasket

▶ cams sold separately. See pg. 128 for cams & grip dimension

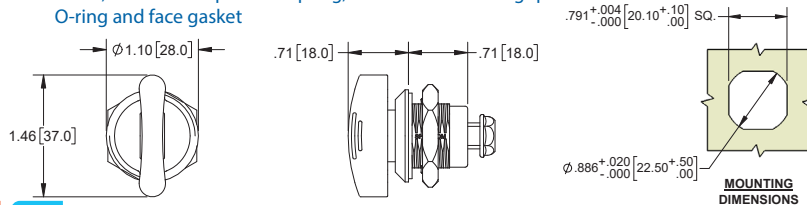

Knob Quarter-turn Latch

316SS NEMA 4x IP65 RATED

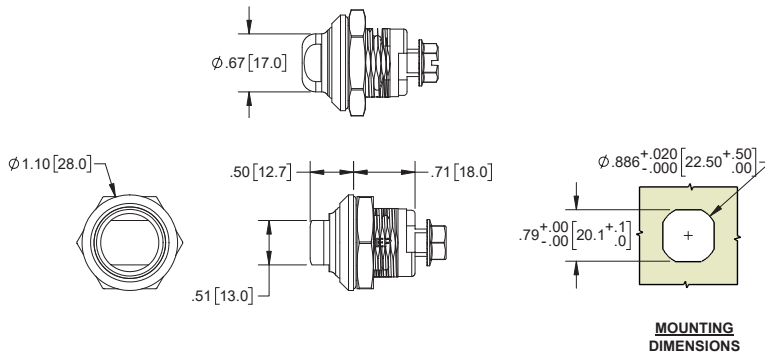

Part Number	Material	Finish
41-40SST	316SS	mill

▶ assembly includes: body nut, face seal, disc spring, small o-ring and large orange o-ring
▶ cams sold separately. See pg. 128 for cams & grip dimension