

### Flush Round Pocket Pull

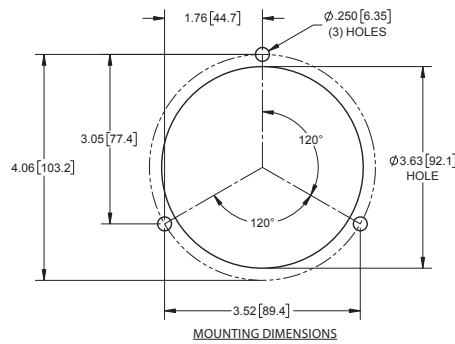

Part Number	Material	Finish
J3006	304SS	brushed

▶ handle edge is hemmed for a more comfortable grip

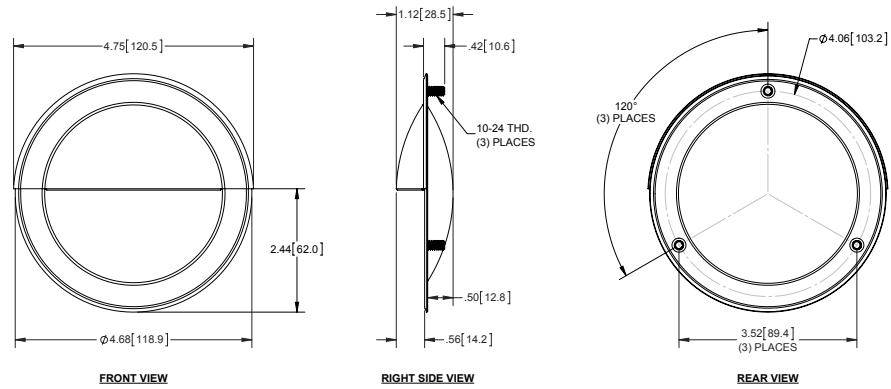

### Flush Pocket Pulls

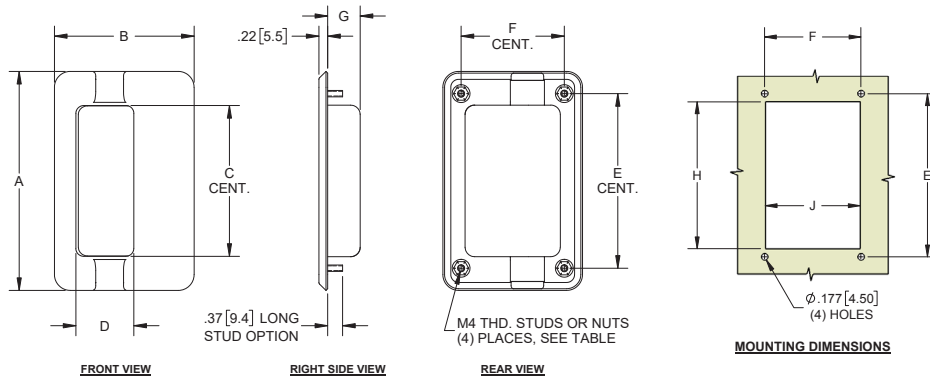

Part No.	Mounting	A	B	C	D	E	F	G	H	J
J3008-1	studs	5.43 [138.0]	3.46 [88.0]	3.74 [95.0]	1.44 [36.5]	4.331 [110.00]	2.559 [65.00]	.81 [20.5]	3.90 [99.0]	2.52 [64.0]
J3008-2	studs	4.37 [111.0]	2.54 [64.5]	2.76 [70.0]	1.10 [28.0]	3.465 [88.00]	1.496 [38.00]	.57 [14.5]	2.87 [73.0]	1.65 [42.0]
J3008-3	studs	3.70 [94.0]	2.36 [60.0]	2.36 [60.0]	1.10 [28.0]	2.992 [76.00]	1.260 [32.00]	.47 [12.0]	2.48 [63.0]	1.69 [43.0]
J3009-1	nuts	5.43 [138.0]	3.46 [88.0]	3.74 [95.0]	1.44 [36.5]	4.331 [110.00]	2.559 [65.00]	.81 [20.5]	3.90 [99.0]	2.52 [64.0]
J3009-2	nuts	4.37 [111.0]	2.54 [64.5]	2.76 [70.0]	1.10 [28.0]	3.465 [88.00]	1.496 [38.00]	.57 [14.5]	2.87 [73.0]	1.65 [42.0]
J3009-3	nuts	3.70 [94.0]	2.36 [60.0]	2.36 [60.0]	1.10 [28.0]	2.992 [76.00]	1.260 [32.00]	.47 [12.0]	2.48 [63.0]	1.69 [43.0]

- ▶ material: 304SS
- ▶ finish: brushed