

Spring Loaded Handle Latch

IP65 RATED NEMA 12

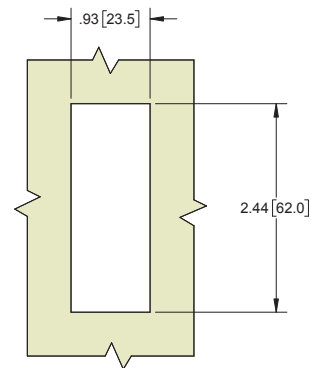
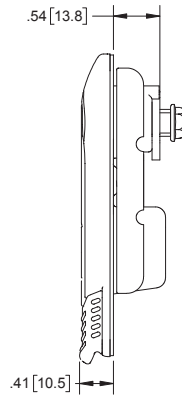
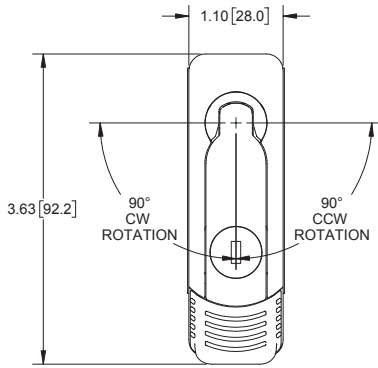

MOUNTING DIMENSIONS
FOR .04 [1.0] - .16 [4.0]
PANEL THICKNESS

Part No.	Key Code	Material	Finish
53BK-02	200	die cast zinc	matte black

- ▶ handle rotation is adjusted by repositioning the 90° stop washer on the rear of the handle
- ▶ cams sold separately. See pg. 134 for cams and grip dimensions

Spring Loaded Handle Latch

IP65 RATED NEMA 12

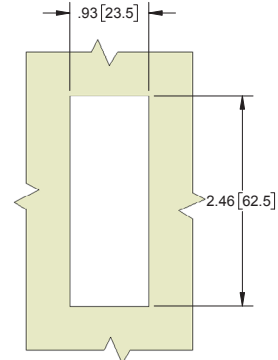
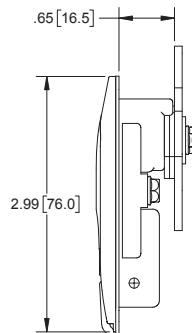
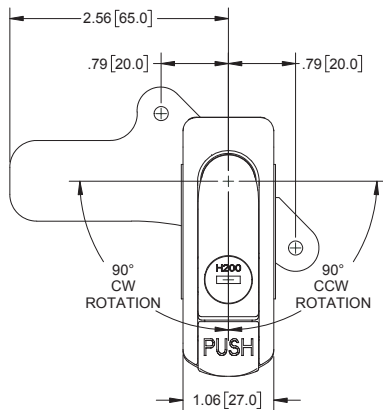

MOUNTING DIMENSIONS
FOR .04 [1.0] - .08 [2.0]
PANEL THICKNESS

Part No.	Key Code	Material	Finish
53G-01	200	zinc die cast	gray

- ▶ handle rotation is adjusted by repositioning the 90° stop washer on the rear of the handle