

Single Point Cams for Swing Handles

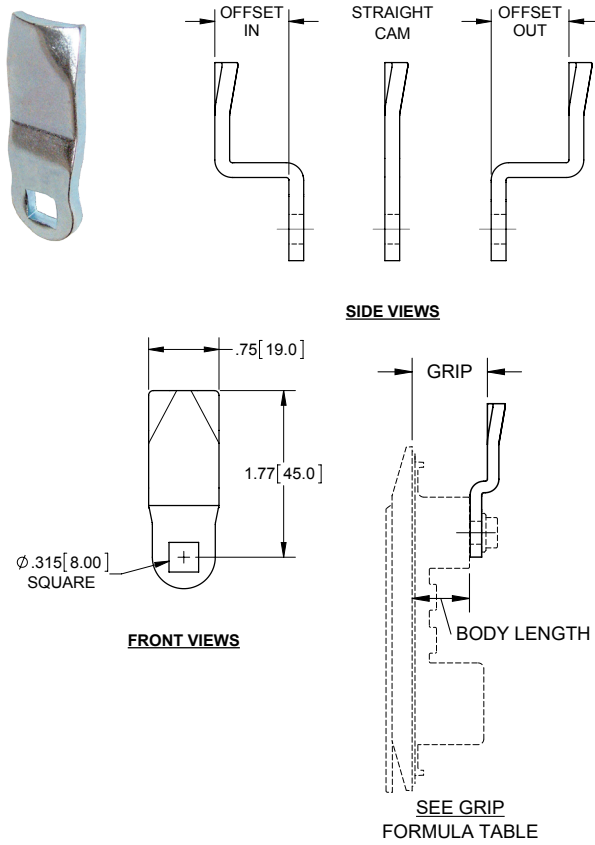

Part Number	Grip	Cam Offset	Part Number	Grip	Cam Offset
50C02	.16 [4.0]	.629 [16.00] in	50C28	1.18 [30.0]	.393 [10.00] out
50C04	.24 [6.0]	.551 [14.00] in	50C30	1.26 [32.0]	.472 [12.00] out
50C06	.31 [8.0]	.472 [12.00] in	50C32	1.34 [34.0]	.551 [14.00] out
50C08	.39 [10.0]	.393 [10.00] in	50C34	1.42 [36.0]	.629 [16.00] out
50C10	.47 [12.0]	.314 [8.00] in	50C35	1.46 [37.0]	.669 [17.00] out
50C13	.59 [15.0]	.196 [5.00] in	50C36	1.50 [38.0]	.708 [18.00] out
50C14	.63 [16.0]	.157 [4.00] in	50C38	1.57 [40.0]	.787 [20.00] out
50C16	.71 [18.0]	.078 [2.00] in	50C40	1.65 [42.0]	.866 [22.00] out
50C18	.79 [20.0]	straight	50C42	1.73 [44.0]	.944 [24.00] out
50C20	.87 [22.0]	.078 [2.00] out	50C44	1.81 [46.0]	1.023 [26.00] out
50C22	.94 [24.0]	.157 [4.00] out	50C45	1.85 [47.0]	1.062 [27.00] out
50C24	1.02 [26.0]	.236 [6.00] out	50C47	1.93 [49.0]	1.141 [29.00] out
50C25	1.06 [27.0]	.275 [7.00] out	50C50	2.05 [52.0]	1.259 [32.00] out
50C26	1.10 [28.0]	.314 [8.00] out			

- ▶ steel, zinc plated
- ▶ grips shown are for latches with .79 [20.0] body length on pages 132 & 133 (see body length table below for .71 [18.0] latch length)
- ▶ may be used with latch adapter part no. 53C00SS on page 126

Grip Formula by Body Length	
Body Length	Dimension to Subtract for Correct Grip
.51 [13.0]	subtract .28 [7.0] to grips on cam table
.71 [18.0]	subtract .08 [2.0] to grips on cam table
.79 [20.0]	same as grips on cam table

Two Point Cam for Swing Handles

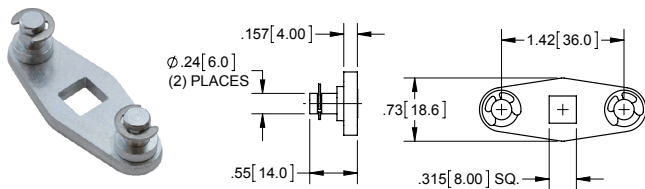

Part Number	Material	Finish
50C00	steel	zinc plated

- ▶ c-clips are supplied with cam
- ▶ refer to page 135 for rods

Three Point Offset Cams for Swing Handles

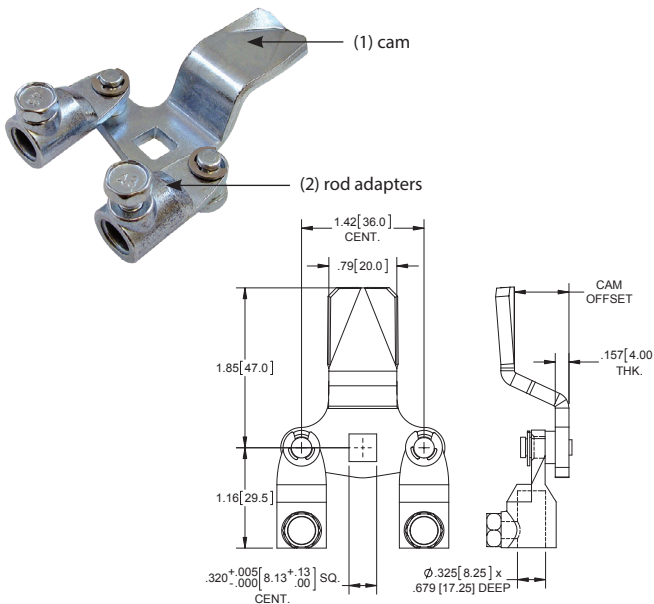

Part Number	Grip	Cam Offset	Body Length	Dimension to Add for Correct Grip
12C43	.79 [20.0]	straight	.69 [17.5]	subtract .10 [2.5] to grips on cam table
12C44	.94 [24.0]	.157 [4.00] out	.71 [18.0]	subtract .08 [2.0] to grips on cam table
12C45	1.10 [28.0]	.315 [8.00] out	.75 [19.1]	subtract .04 [0.9] to grips on cam table
12C46	1.18 [30.0]	.394 [10.00] out	.79 [20.0]	same as grips on cam table
12C47	1.26 [32.0]	.472 [12.00] out	.88 [22.4]	add .09 [2.4] to grips on cam table
12C48	1.34 [34.0]	.551 [14.00] out		
12C40	1.42 [36.0]	.630 [16.00] out		
12C41	1.57 [40.0]	.787 [20.00] out		
12C42	1.65 [42.0]	.866 [22.00] out		

- ▶ steel, zinc plated
- ▶ die cast zinc rod adapter (may be purchased separately as part no. C20)
- ▶ c-clips are supplied with cam
- ▶ use this table to achieve the correct grip for each of the different body lengths
- ▶ refer to page 135 for rods