

Flat Connecting Rods

Part Number	Length	Material	Finish
748-7.8	7.87 [200.0]	steel	zinc plated
748-23.6	23.62 [600.0]	steel	zinc plated
748-31.5	31.50 [800.0]	steel	zinc plated
748-47.2	47.24 [1200.0]	steel	zinc plated

- ▶ brass studs
- ▶ for use with round or through hole type rod controls on previous page

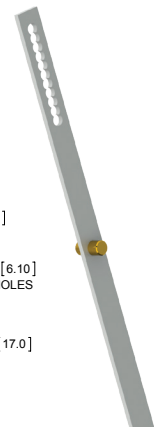
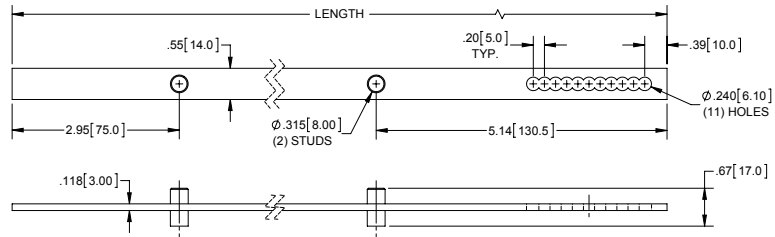

Flat Connecting Rod with Wheels

Part Number	Material	Finish
746-43.3	steel	zinc plated

- ▶ custom lengths can be made to your specifications
- ▶ for use with square stud rod control on previous page

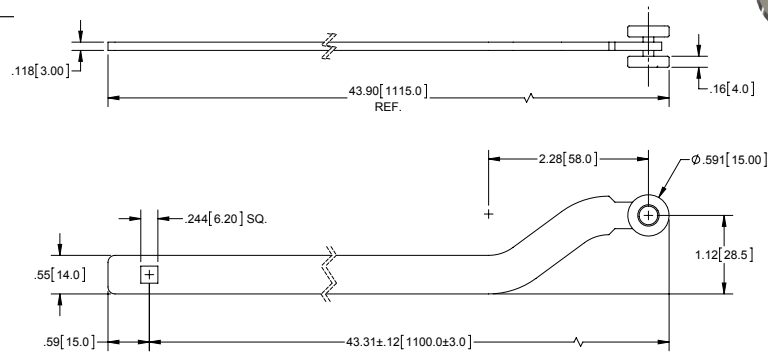

Rod Guide & Rod Keeper

Rod Guide

Part Number	Material	Finish
702-07	plastic	black, smooth

- ▶ used on connecting rods on the top of this page

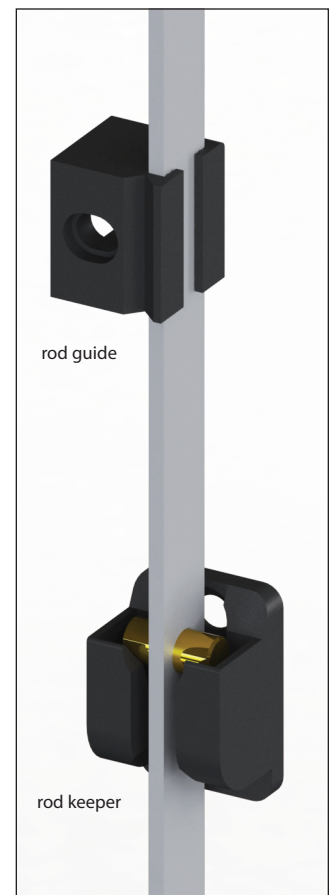
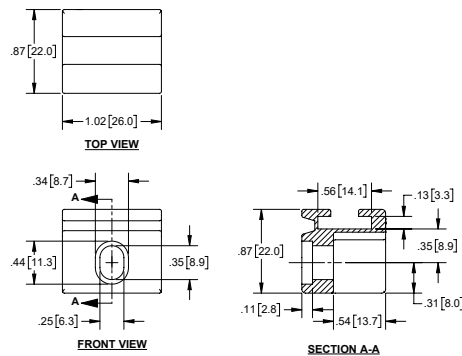

Rod Keeper

Part Number	Material	Finish
702-10	die cast zinc	black powder coated

- ▶ used on connecting rods on the top of this page

