

316SS

### Compression Spring and Over Center Latch with Padlock Eye

Part Number	Description	Material	Finish
2032SS-L	tab up latch	304SS	passivated
2032SS-L03	tab up latch	316SS	passivated
2032SS	tab up latch & keeper	304SS	passivated

▶ see below for keeper (sold separately)

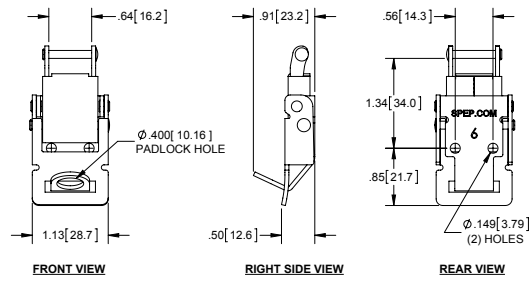

Part Number	Description	Material	Finish
2032SS-K	keeper	304SS	passivated
2032SS-K01	keeper	316SS	passivated

▶ see table for the distance that relates to the desired tension

Desired Tension	D
30 lbs.	1.813 [46.05]
40 lbs.	1.844 [46.84]
50 lbs.	1.875 [47.63]

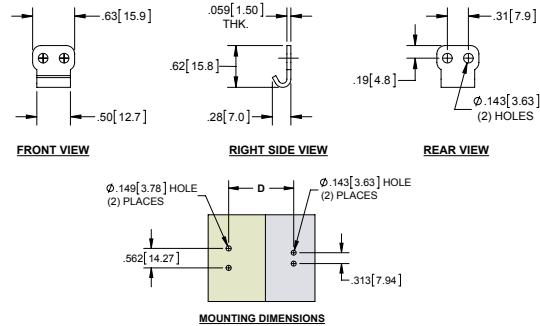

316SS

### Keepers

Part Number	Material	Finish
2175	steel	zinc plated

▶ no mounting holes, welded in place

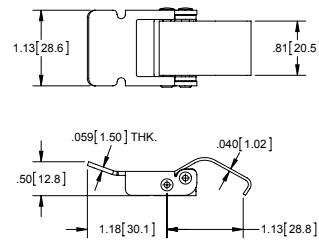

### Over Center Latch

Part Number	Description	Material	Finish	Padlocking
2176	latch	steel	clear zinc	no
2176-01	latch	steel	clear zinc	yes
2177	mounting plate	steel	mill	no
2177-01	mounting plate	steel	mill	yes

- ▶ parts sold separately
- ▶ part no. 2177 has no holes and must be welded in place
- ▶ part no. 2177-01 may be screwed or welded in place

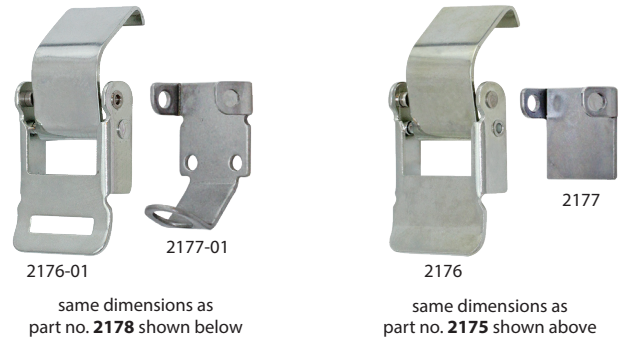

### Over Center Latch Kit

Part Number	Material	Finish
2178ZN	steel	zinc plated
2178SS	304SS	passivated

