

Over Center Latch

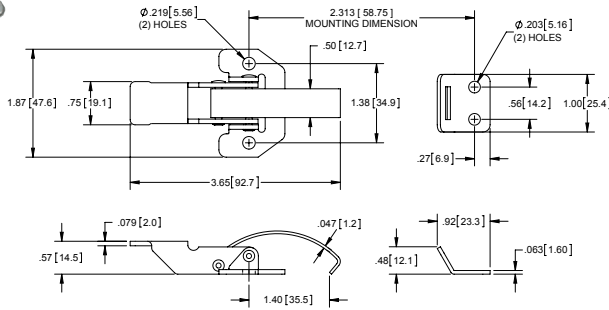
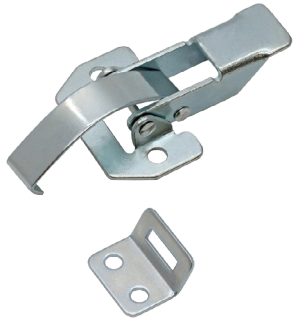

Latch

Part Number	Description	Material	Finish
213	latch	steel	zinc plated

Keeper

Part Number	Description	Material	Finish
2131	keeper	steel	zinc plated

Over Center Latch with a Radial Base

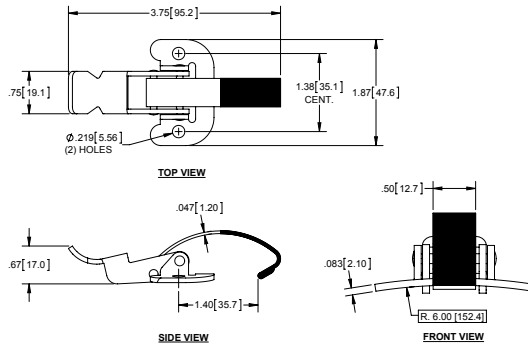

Part Number	Material	Finish	PVC Coating
214	steel	zinc plated	yes
214-01	steel	zinc plated	no

▶ ideal for cylindrical containers

Over Center Latch with a Radial Base

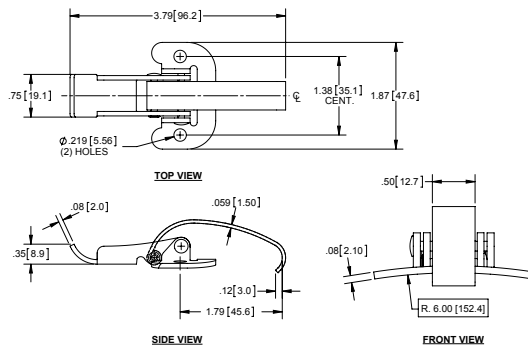

Part Number	Description	Material	Finish
214-02	latch	steel	zinc plated

▶ latch has reversed lever
▶ ideal for cylindrical containers

Large Compression Pull Down Catch with Holes for Fixed or Adjustable Mounting

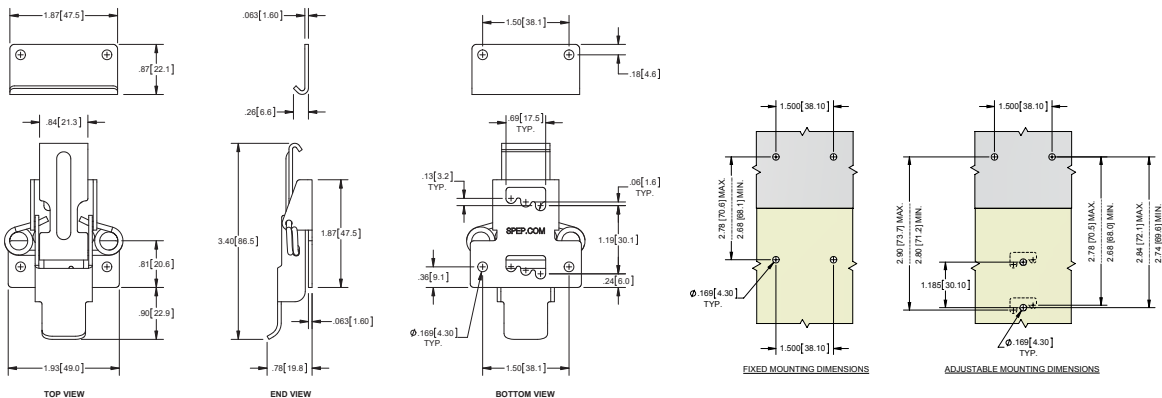
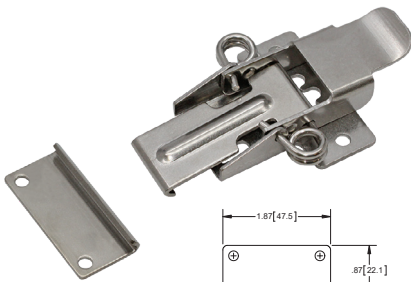

Part Number	Description	Material	Finish
2141ZN-L	latch	steel	zinc plated
2141SS-L	latch	304SS	passivated
2141ZN-K	keeper	steel	zinc plated
2141SS-K	keeper	304SS	passivated