

Over Center Latch with Padlock Eye

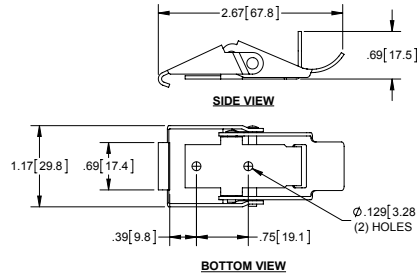

Latch

Part Number	Material	Finish
2189SS	304SS	electropolished

▶ .375" diameter padlock hole

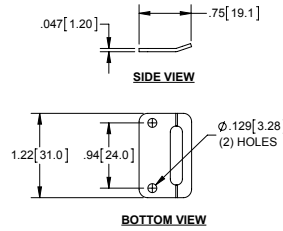

Striker

Part Number	Material	Finish
2188SS01	304SS	electropolished

▶ accepts .125" rivet

Heavy Duty Draw Pull Latch

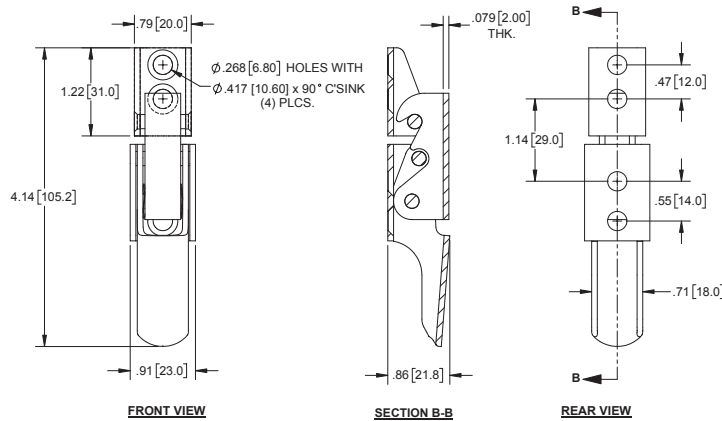

Part Number	Material	Finish
2065SS	304SS	mill

▶ working load: 154 lbs.

Adjustable Plastic Draw Latch

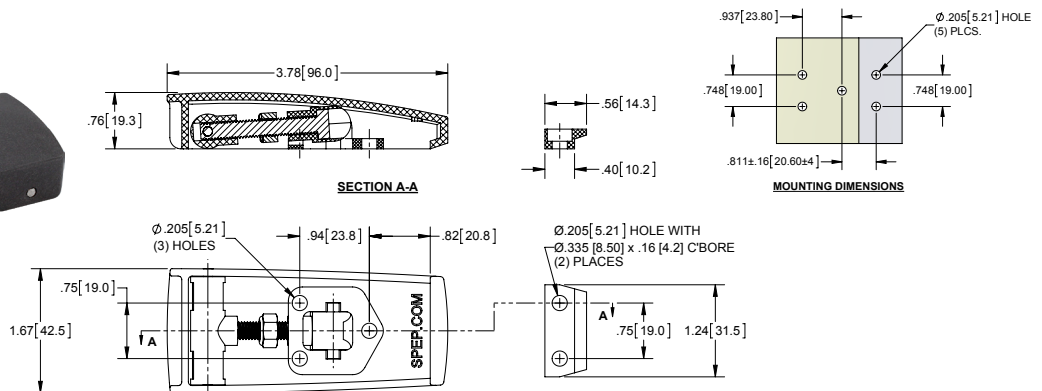

Part Number	Description	Material	Finish
239BK	latch and keeper	glass reinforced acetal	lightly textured black

▶ concealed keeper