

### Large Adjustable Under Center Latch with Keeper

Part Number	Material	Finish
2173ZN	steel	zinc plated

- ▶ keeper is stainless steel
- ▶ working load: 1,000 lbs.
- ▶ latch and keeper surfaces must be on the same plane

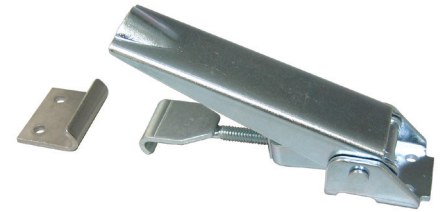
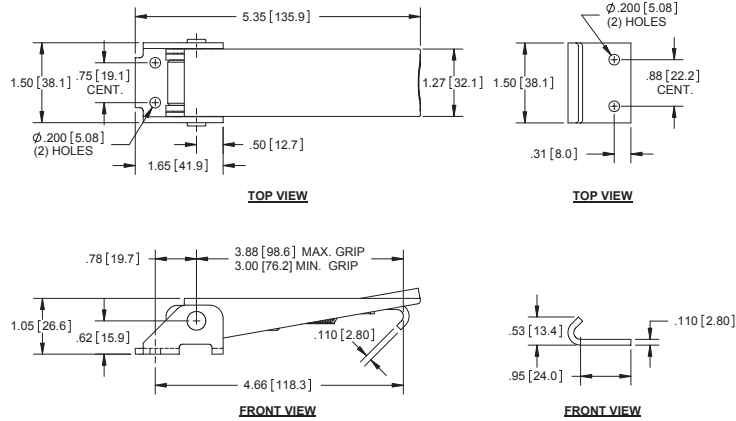

### Large Adjustable Under Center Latches

Part Number	Description	Material	Finish
2173SS-L01	latch	300 series stainless steel	electropolished
2173SS-K	keeper	304SS	mill

- ▶ working load: 1,000 lbs.
- ▶ latch and keeper surfaces must be on the same plane
- ▶ keeper details are the same as part number 2173ZN shown above

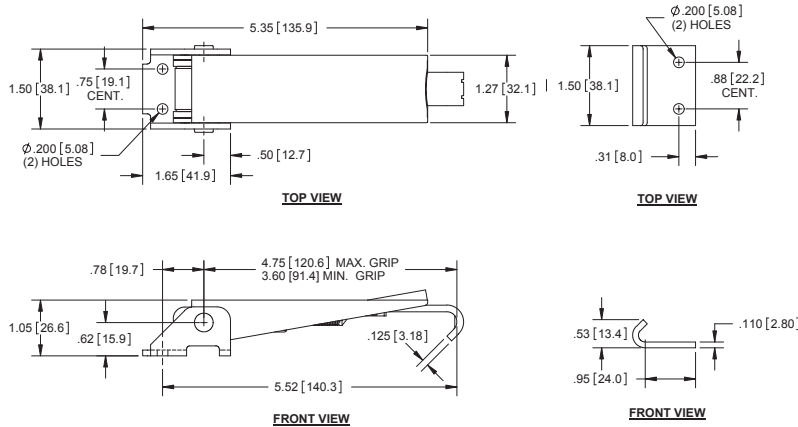

### Adjustable Under Center Latches

Part No.	Description	Material	Finish
2075ZN-L	latch	steel	yellow zinc plated
2075ZN-S	striker	steel	yellow zinc plated

- ▶ working load: 1500lbs.

