

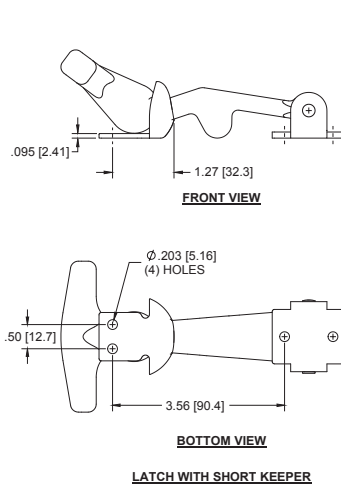

Extra Large EPDM Rubber T-Handle Latches

Part Number	Keeper Style	Description	Keeper Material	Keeper Finish
220-400SS	long	fixed assembled (riveted)	304SS	passivated
220-400ZN	long	fixed assembled (riveted)	steel	zinc plated
220-400SS50	long	unassembled (cotter pin)	304SS	passivated
220-400ZN50	long	unassembled (cotter pin)	steel	zinc plated
220-450SS	short	fixed assembled (riveted)	304SS	passivated
220-450ZN	short	fixed assembled (riveted)	steel	zinc plated
220-450SS50	short	unassembled (cotter pin)	304SS	passivated
220-450ZN50	short	unassembled (cotter pin)	steel	zinc plated
230-4T	---	t-handle only		

- ▶ dimensions shown are after installation
- ▶ long keeper includes (2) small weld guides

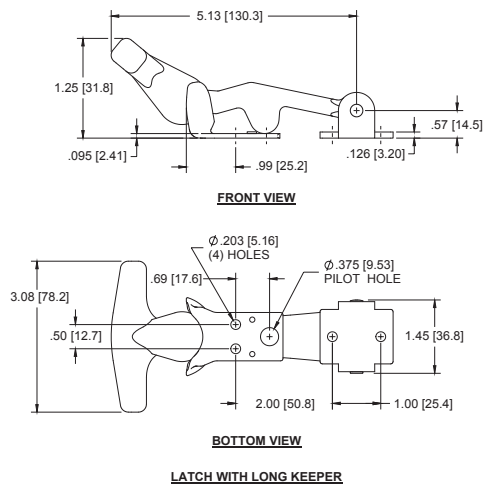

UV Extra Large EPDM Rubber T-Handle Latches

Part Number	Keeper Style	Keeper Material	Keeper Finish
220-500SS	long	304SS	passivated
220-500ZN	long	steel	zinc plated
220-550SS	short	304SS	passivated
220-550ZN	short	steel	zinc plated

- ▶ dimensions shown are after installation

