

Aluminum Bolt Latch

Part Number	Material	Finish
1184A-02	aluminum	mill

- ▶ Ø .3750 [9.53] bolt
- ▶ 304SS spring, washer and roll pin

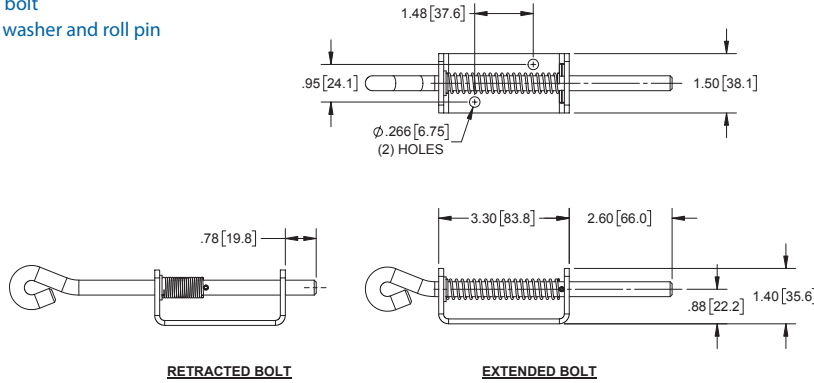

Bolt Latch with Stop Pin

Part Number	Material	Finish
11832ZN-03	steel	zinc plated

- ▶ red PVC rubber grip
- ▶ Ø .500 [12.70] bolt

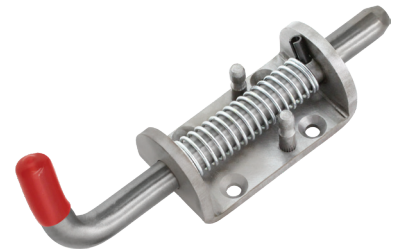
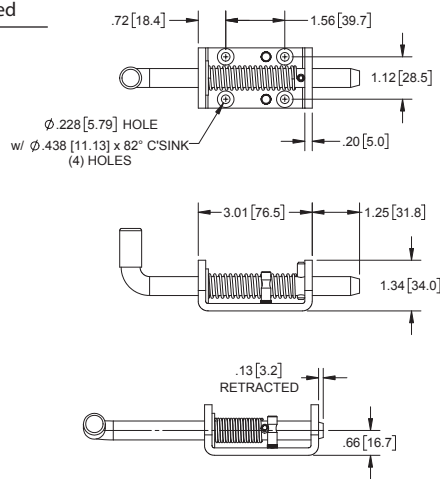

Bolt Latch with Keeper

Part Number	Material	Finish	Description
1261ZN	steel	zinc plated	latch & keeper
1261ZN-01	steel	zinc plated	latch only
NEW 1261SS	304SS	passivated	latch & keeper

- ▶ Ø .500 [12.70] steel bolt

