

Three Point Cabinet Latches with Tubular Rods

Build Your Own Cabinet Latch Kit

708 A 762-11.375 → Example Part No.

- rod part numbers (2 pcs.) (see tubular rod options below)
- cam style
- base part number includes:
 - 710 adjustable rod guide (2pcs.)
 - 760 5/16-18 shoulder bolt (2pcs.)

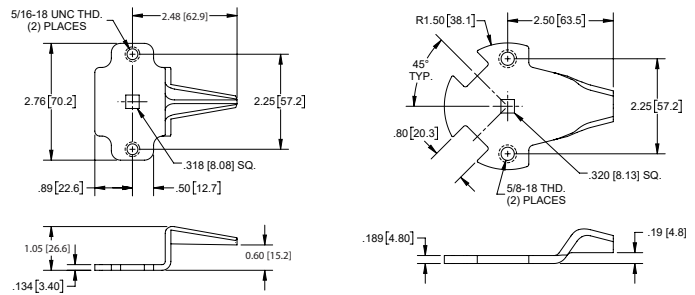

Center Cam Options		
Options	Part No.	Description
A	700	.60 [15.2] offset center cam
B	700-01	.187 [4.75] offset center cam
C	701	adjustable nylon roller center cam
D	701-01	adjustable nylon roller center cam with weld collar

Tubular Rod Options				
Part No.	Dimension A	Dimension B	Dimension C	Material
762	18.83 [478.3]	6.00 [152.4]	3.00 [76.2]	steel
762SS	18.83 [478.3]	6.00 [152.4]	3.00 [76.2]	304 SS
762-11.375	11.38 [289.1]	N/A	N/A	steel
762-12.875	12.88 [327.2]	N/A	N/A	steel
762-12.937	12.94 [328.7]	6.00	3.00	steel
762-15.75	15.75 [400.1]	N/A	N/A	steel
762-7.875	7.88 [200.2]	N/A	N/A	steel
765	33.83 [859.3]	6.00 [152.4]	6.00 [152.4]	steel
765SS	33.83 [859.3]	6.00 [152.4]	6.00 [152.4]	304SS
765-15.875	15.88 [403.4]	N/A	N/A	steel
765-15.937	15.94 [404.9]	6.00 [152.4]	6.00 [152.4]	steel
765-18.25	18.25 [463.6]	6.00 [152.4]	6.00 [152.4]	steel
765-18.875	18.88 [479.6]	N/A	N/A	steel
765-23.875	23.88 [606.6]	N/A	N/A	steel
765-24.875	24.88 [632.0]	6.00 [152.4]	6.00 [152.4]	steel
765-29.875	29.88 [759.0]	N/A	N/A	steel
765-9.875	9.88 [251.0]	N/A	N/A	steel
768	45.83 [1164.1]	3.00 [76.2]	3.00 [76.2]	steel
768SS-01	45.83 [1164.1]	3.00 [76.2]	3.00 [76.2]	304SS
768-21.875	21.88 [555.8]	N/A	N/A	steel
768-27.875	27.88 [708.2]	N/A	N/A	steel
768-30.06	30.06 [763.5]	N/A	N/A	steel
768-33.875	33.88 [860.6]	N/A	N/A	steel
768-38.875	38.88 [987.6]	N/A	N/A	steel
768-39.19	39.19 [995.4]	N/A	N/A	steel
768-41.50	41.50 [1054.1]	N/A	N/A	steel
768-41.875	41.88 [1063.8]	N/A	3.00	steel
768-44.375	44.38 [1127.3]	3.00 [76.2]	3.00 [76.2]	steel
769	49.00 [1244.6] total center to end rod length	no holes		steel
768SS	46.21 [1173.7] total center to end rod length	no holes		304SS

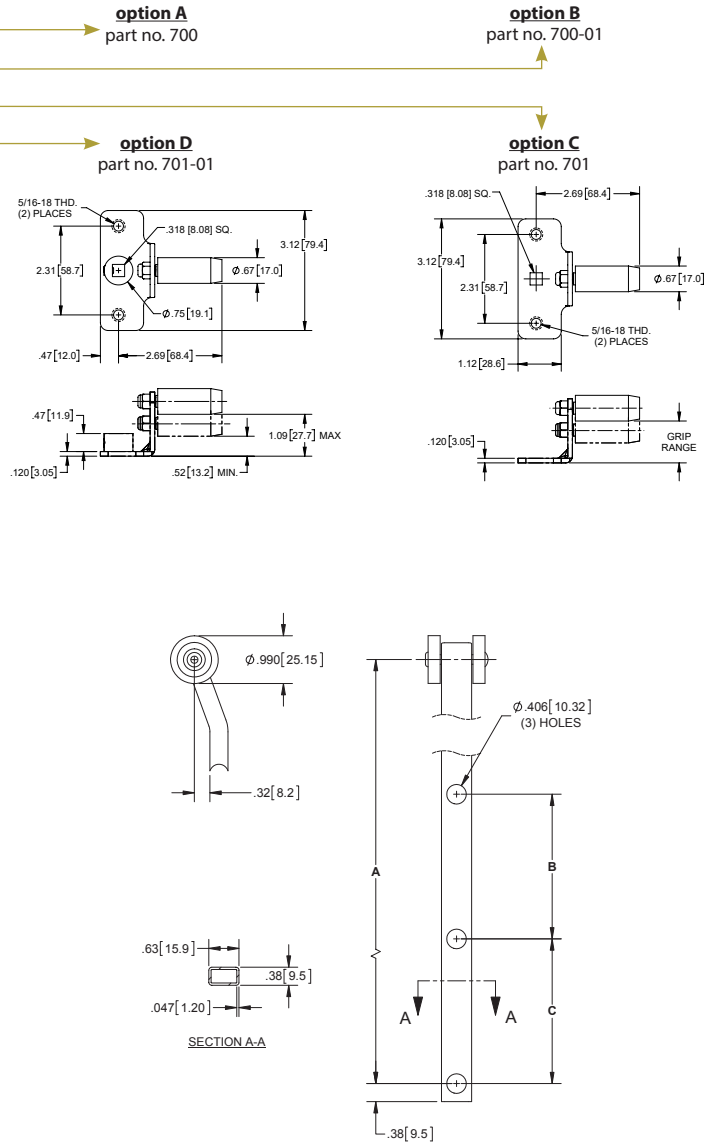

- ▶ easy installation
- ▶ nylon rollers for smooth operation
- ▶ rods can be made to custom lengths and hole patterns if order volume is sufficient
- ▶ steel rods finish: zinc plated ▶ 304SS rods finish: mill