

Die Cast Offset Pull

Part Number	Material	Finish
988CH	die cast zinc	chrome plated

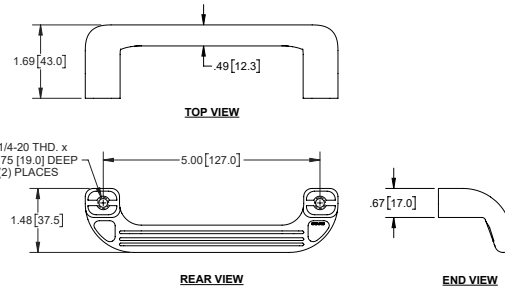

Plastic Pull

Part No.	Holes	Material	Finish
989BK	hex	reinforced nylon	black textured
989BK-02	c'sunk	reinforced nylon	black textured

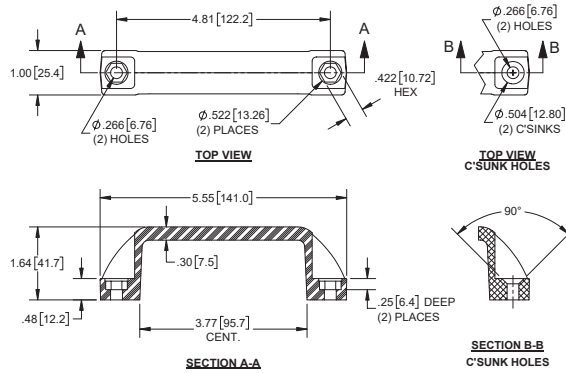

Plastic Pull

Part Number	Material	Finish
989BK10	reinforced nylon	black textured

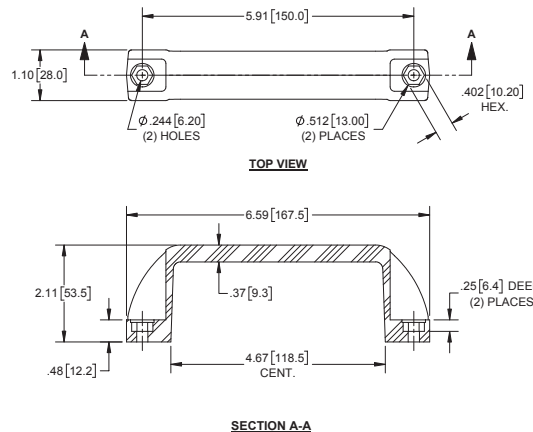

Plastic Pull

Part Number	Material	Finish
964P	plastic	black

