

JIC Clamp Bracket

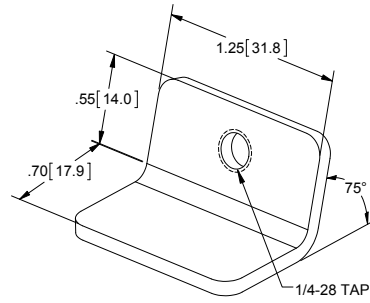

Part Number	Material	Finish	Thread	Material Thickness
182	steel	mill	1/4-28	.098 [2.50]
182SS	304SS	tumbled	1/4-28	.105 [2.67]
182SS01	316SS	tumbled	1/4-28	.105 [2.67]

JIC Cover Clamp

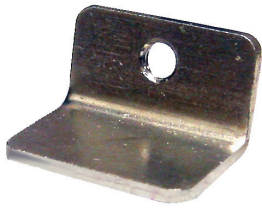
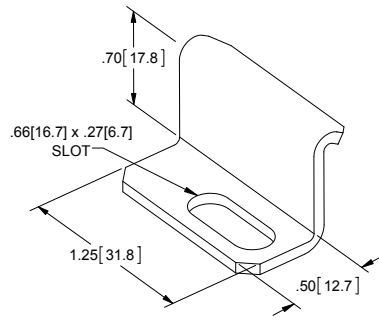
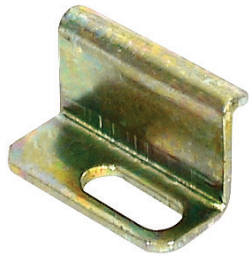

Part Number	Material	Finish	Material Thickness
162N	steel	yellow zinc plated	.074 [1.88]
16SS	304SS	tumbled	.074 [1.88]
16SS-01	316SS	tumbled	.074 [1.88]

JIC Padlock Box Staples

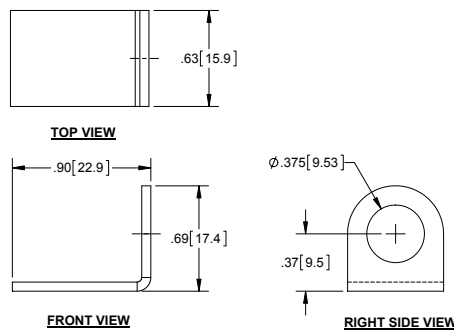

Part Number	Material	Finish	Material Thickness
J3061	steel	mill	.063 [1.60]
J3061SS	304SS	tumbled	.063 [1.60]

JIC Padlock Cover Staples

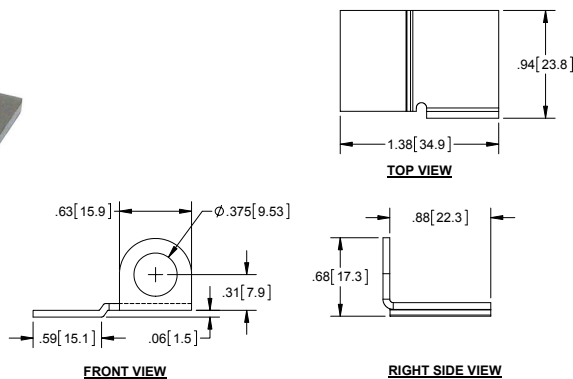

Part Number	Material	Finish	Material Thickness
J3060	steel	mill	.063 [1.60]
J3060SS	304SS	tumbled	.063 [1.60]