

Die Cast Zinc Hinge Block

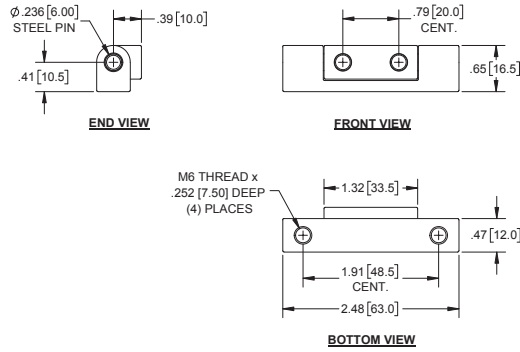

Part No.	Material	Finish
H2276BK	die cast zinc	black powder coated

▶ steel pin with nickel plated finish

Concealed Hinge

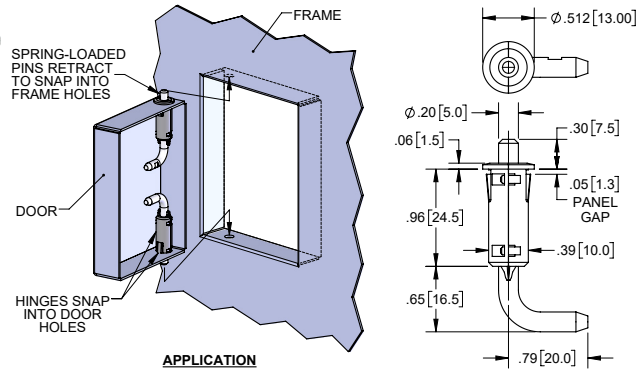

Part Number	Housing		Pin	
	Material	Finish	Material	Finish
D446	plastic	black	die cast zinc	zinc pated

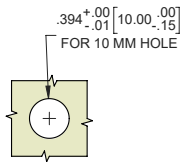

Hinge Block

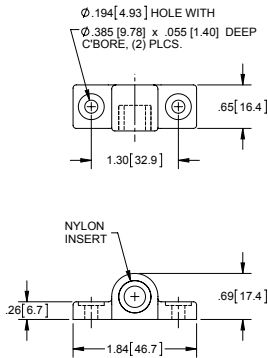

Part Number	Material	Finish
955S	304SS	mill

▶ accepts a .313 [7.94] diameter rod

Plastic Hinge Block

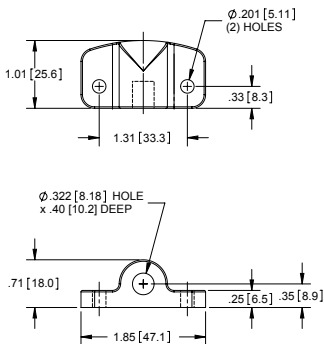

Part Number	Material	Finish
95P	plastic	natural

▶ accepts a .313 [7.94] diameter rod

Hinge Block

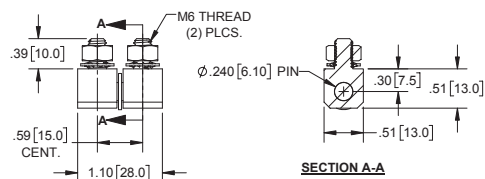

Part No.	Material	Finish
H2260	steel	zinc plated