

1.65 [42.0] Lift-off Hinge, Die Cast Zinc

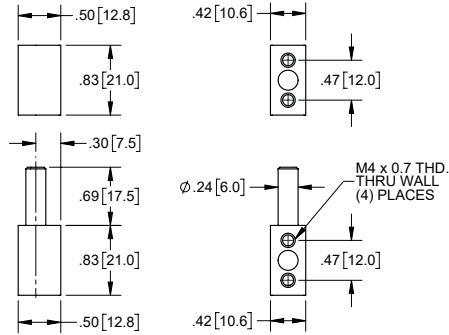

Part No.	Material	Finish
ML39	die cast zinc	matte black
▶ steel, zinc plated pin		

2.36 [60.0] Offset Lift-off Hinge, Die Cast Zinc

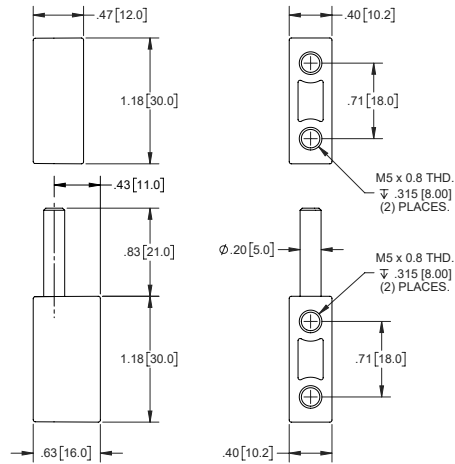

Part No.	Material	Finish
ML14CH	die cast zinc	bright chrome plated
▶ steel, nickel plated pin		

2.56 [65.0] Lift-off Hinge, Die Cast Hinge

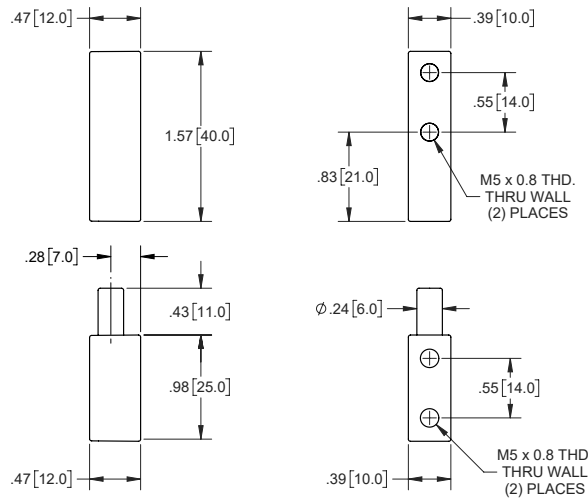

Part No.	Material	Finish
ML47CH	die cast zinc	bright chrome plated
▶ pin & body are one solid piece		

2.41 [61.1] Offset Lift-off Hinge, Die Cast Zinc

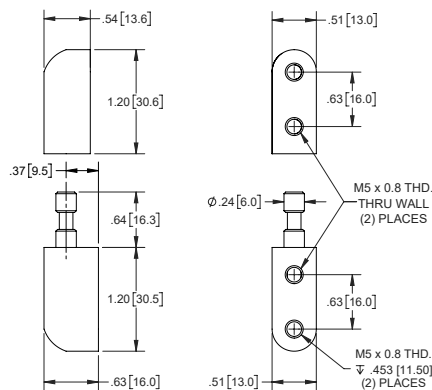

Part No.	Material	Finish
ML48CH	die cast zinc	bright chrome plated
▶ pin & body are one solid piece		