

2.50 [63.5] Offset Lift-off Hinges with Threaded Holes



part number: **ML05**
left hand



part number: **ML06**
right hand

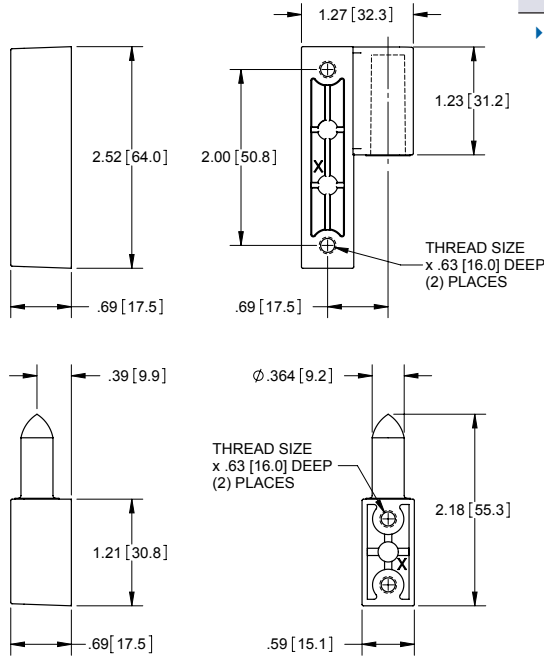

Part Number	Description	Material	Finish	Thread Size
ML05	left hand	die cast zinc	matte black powder coat	10-32
ML06	right hand	die cast zinc	matte black powder coat	10-32
ML05-01	left hand	die cast zinc	matte black powder coat	M5
ML06-01	right hand	die cast zinc	matte black powder coat	M5

▶ includes Delrin washer

2.50 [63.5] Offset Lift-off Hinges with Through Holes



part number: **ML07**
left hand



part number: **ML08**
right hand

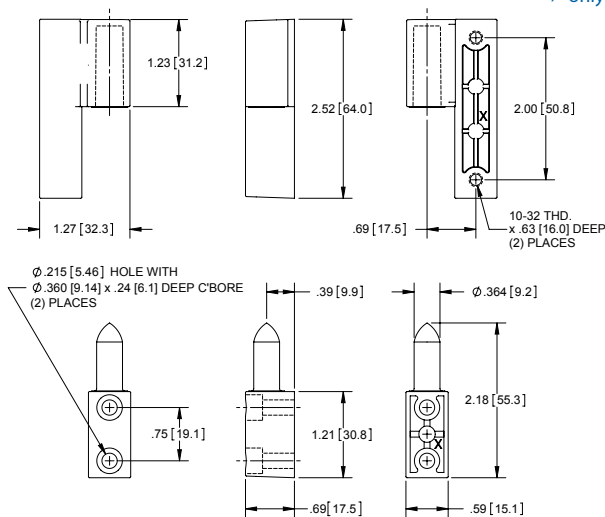

Part Number	Description	Material	Finish
ML07	left hand	die cast zinc	matte black powder coat
ML08	right hand	die cast zinc	matte black powder coat

- ▶ includes Delrin washer
- ▶ (2) rubber caps (part no. **ML30-C**)
- ▶ only female leaf has through holes