

Mini 1.00 [25.4] Offset Lift-off Hinges

Part Number	Description	Material	Finish	Thread Size
ML45	left hand	die cast zinc	matte black powder coat	6-32
ML45-01	left hand	die cast zinc	matte black powder coat	M4 x .7
ML46	right hand	die cast zinc	matte black powder coat	6-32
ML46-01	right hand	die cast zinc	matte black powder coat	M4 x .7

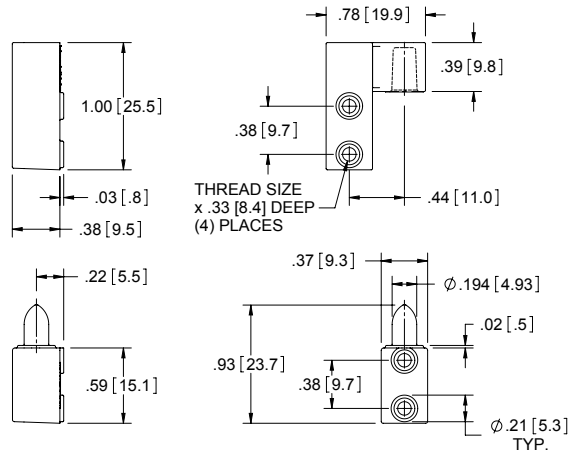

part number: **ML45**
left hand



part number: **ML46**
right hand

Mini 1.13 [28.6] In-Line Lift-off Hinges

Part Number	Material	Finish	Thread Size
ML42	die cast zinc	matte black powder coat	6-32
ML42-01	die cast zinc	matte black powder coat	M4 x .7

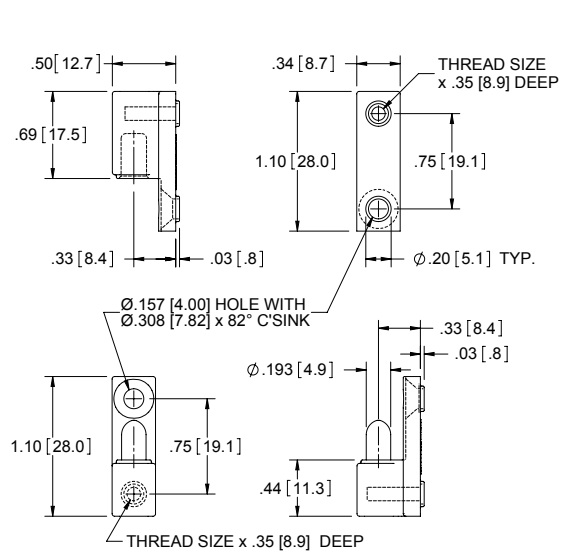

2.50 [63.5] Lift-off Hinges

Part Number	Material	Finish	Thread Size
ML02	die cast zinc	matte black powder coat	10-32
ML02-02	die cast zinc	matte black powder coat	M5
ML02-02SS	304SS	passivated	M5
ML02-03	die cast zinc	matte black powder coat	Ø.172 plain holes

- ▶ includes Delrin washer
- ▶ **ML02** components may be purchased separately
- ▶ gaskets available separately as part no. **ML02G**

