

Two-Piece Aluminum Door Hold-Backs

No Spring Kits

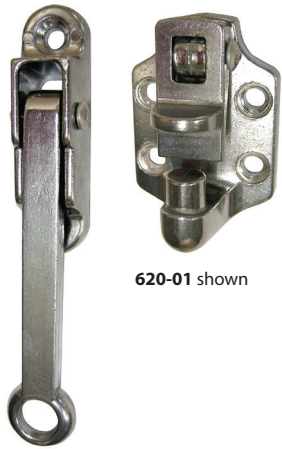

620-01 shown

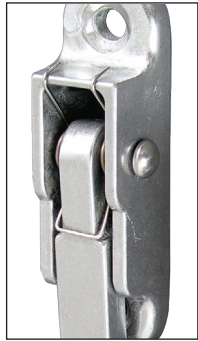
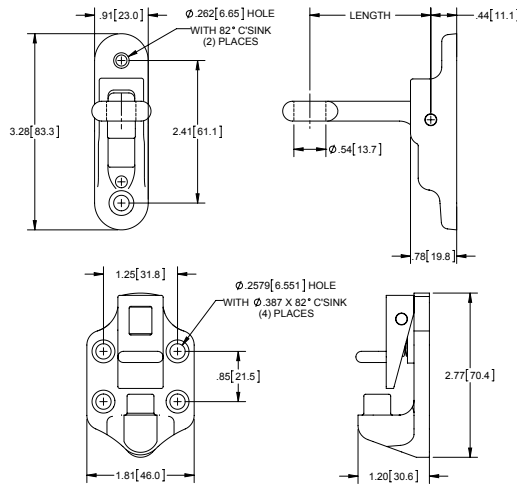

NOTE: the 622-Series has a spring loaded arm to keep it from rattling

Part Number	Length	Finish
620	2.00 [50.8]	tumbled polished
620-01	4.00 [101.6]	tumbled polished
620-03	6.00 [152.4]	tumbled polished
620-07	10.00 [254.0]	tumbled polished
620BK	2.00 [50.8]	black e-coated
620BK-01	4.00 [101.6]	black e-coated
620BK-03	6.00 [152.4]	black e-coated
620BK-07	10.00 [254.0]	black e-coated

- ▶ two-piece kits are packaged inside a sealed polybag
- ▶ 300 series stainless steel pins

Spring Loaded Kits

Part Number	Length	Finish
622	2.00 [50.8]	tumbled polished
622-01	4.00 [101.6]	tumbled polished
622-03	6.00 [152.4]	tumbled polished
622-07	10.00 [254.0]	tumbled polished

Three-Piece Aluminum Ball and Socket Door Hold-Backs



621-01 shown

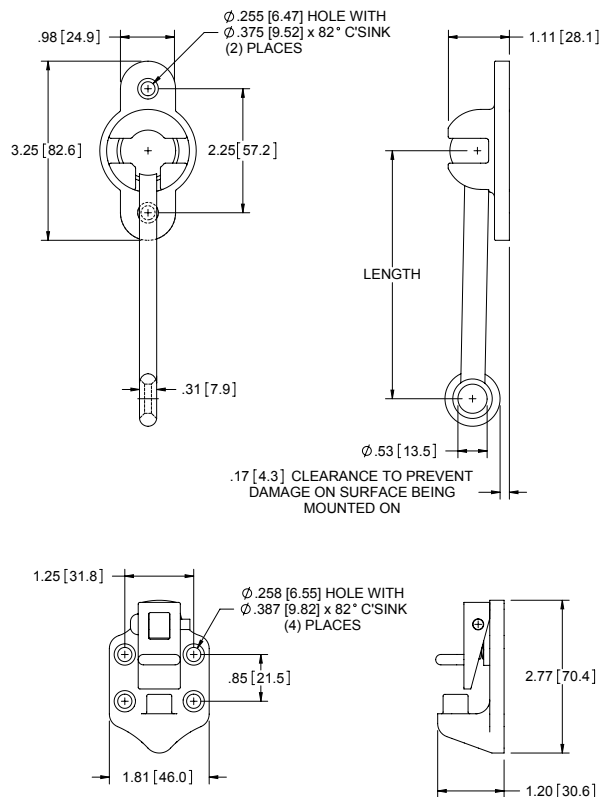

Part Number	Length	Finish
621	2.00 [50.8]	black e-coated
621P	2.00 [50.8]	tumbled polished
621-01	4.50 [114.3]	black e-coated
621P-01	4.50 [114.3]	tumbled polished
621-03	6.00 [152.4]	black e-coated
621P-03	6.00 [152.4]	tumbled polished
621-07	10.00 [254.0]	black e-coated
621P-07	10.00 [254.0]	tumbled polished

- ▶ three-piece kits are packaged inside a sealed polybag
- ▶ 300 series stainless steel pins