

Small Folding Steps

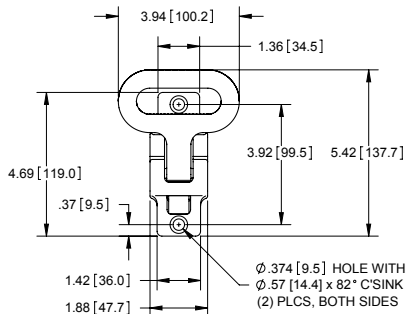

FRONT VIEW

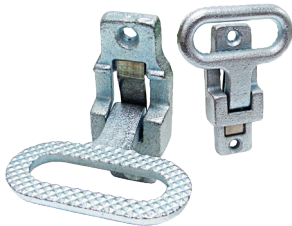
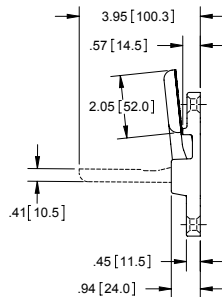

RIGHT SIDE VIEW

Part Number	Material	Finish
875SS	304SS	electro-polished
875ZN	cast steel	zinc plated
875BK	cast steel	black e-coated

- ▶ meets or exceeds 49 CFR Section 399 FMCSA for serrated step surface slip resistant design and min. static working load requirement of 204kg/450lbs

Large Folding Step with Gasket

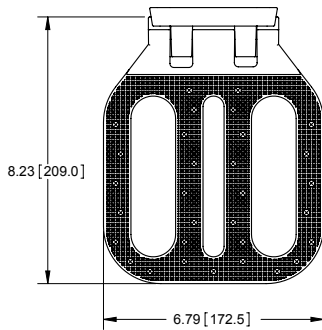
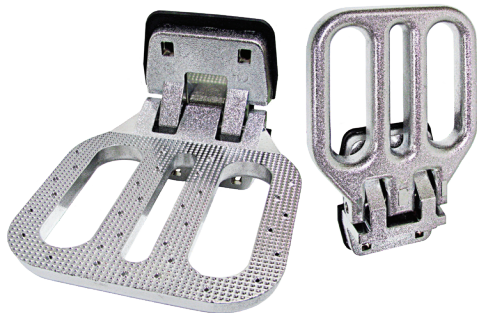

TOP VIEW

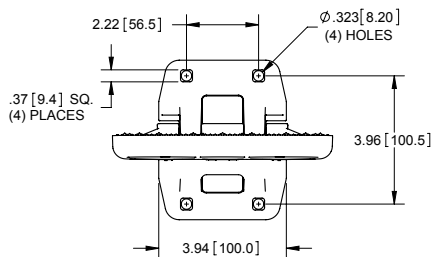

FRONT VIEW

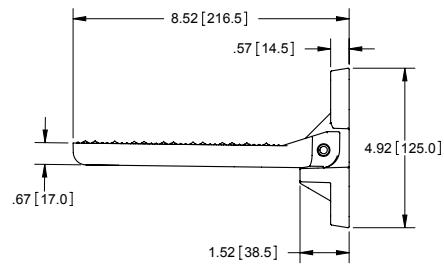

RIGHT SIDE VIEW

Part Number	Material	Finish
874CH	die cast zinc	textured chrome

- ▶ includes gasket
- ▶ meets or exceeds 49 CFR Section 399 FMCSA for serrated step surface slip resistant design and min. static working load requirement of 204kg/450lbs

Large Folding Step PAT.



patented

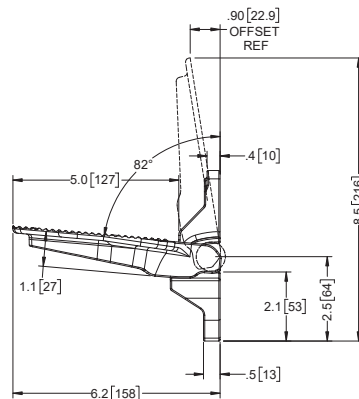
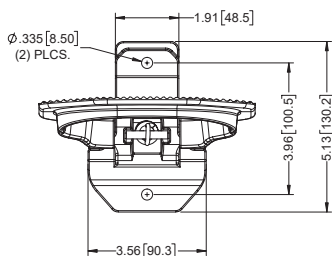
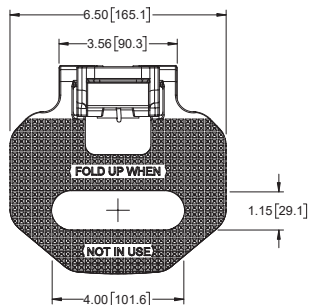

Part Number	Material	Finish
876ZN	steel	zinc plated

- ▶ meets or exceeds 49 CFR Section 399 FMCSA for serrated step surface slip resistant design and min. static working load requirement of 204kg/450lbs