

## Single Point T-Handles

Part Number	Key Code	Pan Thickness	Finish
486RH-01ZP	non-locking	18 gauge	clear zinc plated
486LH-01ZP	non-locking		
486RH-751BK	CH751		black matte powder coated
486LH-751BK	CH751		

- ▶ material: steel
- ▶ locking part numbers include cam lock with (2) ringed keys
- ▶ cam has multiple holes for optional multi-point installation
- ▶ features adjustable cam
- ▶ see page 63 for rods

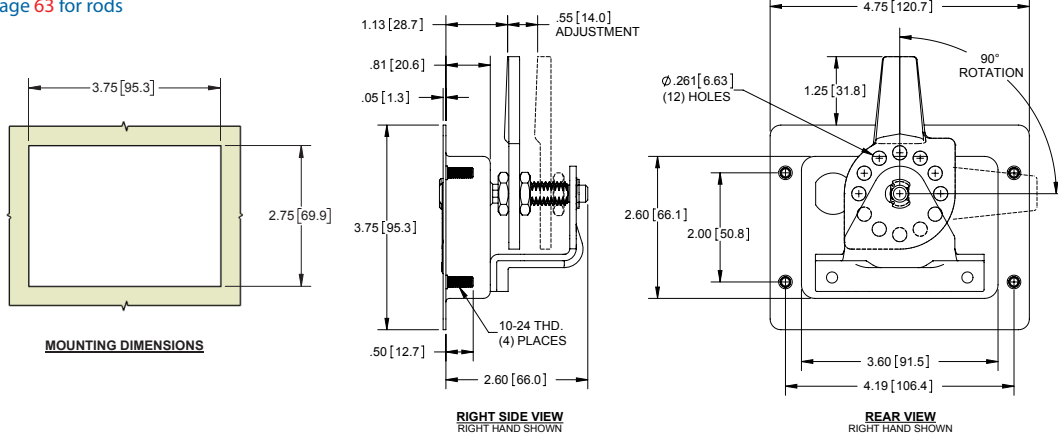
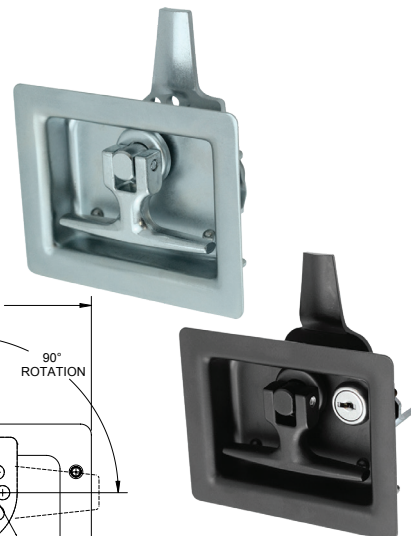

Refer to existing part family on page 70