

Single Point T-Handles

Part No.	Material	Finish	Holes	Pan Thickness
491	steel	zinc plated	yes	18 gauge
491SS	304SS, pan only	polished	yes	18 gauge

- ▶ 360° handle rotation
- ▶ die cast zinc handle
- ▶ see accessories starting on pg. 58
- ▶ use cams on pg. 60 & 61
- ▶ use push-on nut on pg. 59

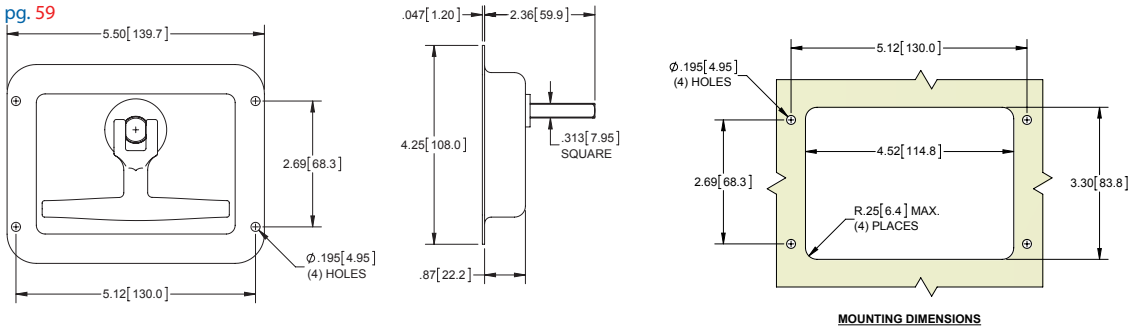

Single Point Folding T-Handle

Part Number	Material	Finish
495-01	304SS pan	deburred

- ▶ die cast zinc handle
- ▶ 18 gauge pan
- ▶ includes mounting hardware
- ▶ accepts up to 3/8" padlock

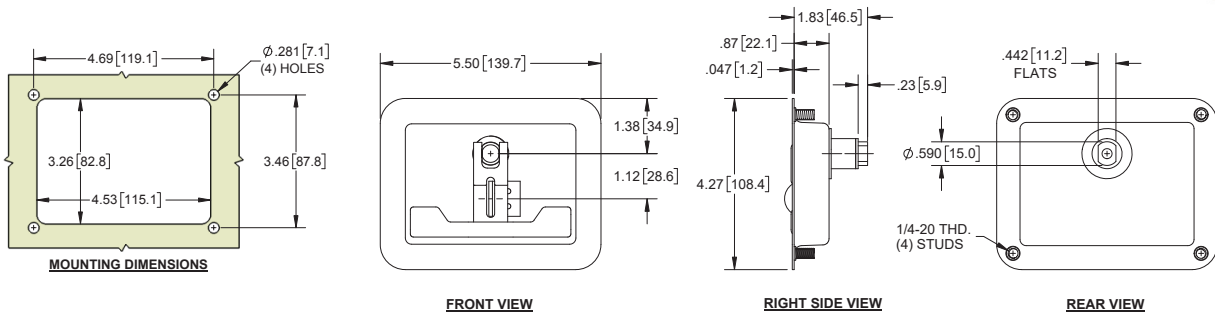

Single Point Padlocking T-Handles

Part Number	Material / Finish	Mounting Holes
481P	steel / zinc	no
481PSS	304SS pan only / polished	yes

- ▶ 18 gauge pan thickness
- ▶ die cast zinc handle
- ▶ accepts up to 5/16" padlock

