

Snap-in Magnetic Catches

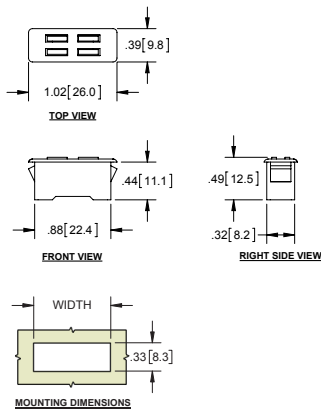

Part Number	Color	Holding Force lbf [N]	Panel Thickness	Cut-out Width
D407G	gray	approx. 4.9 [21.6]	.0197 ±.002 [.500 ±.05]	.89 ±.006 [22.6 ±.15]
D407W	white	approx. 2.9 [12.8]	.0315 ±.002 [.800 ±.05]	.93 ±.006 [23.6 ±.15]
D408G	gray	approx. 4.9 [21.6]	.0394 ±.002 [1.000 ±.05]	.89 ±.004 [22.6 ±.10]
D408W	white	approx. 2.9 [12.8]	.0472 ±.002 [1.200 ±.05]	.93 ±.004 [23.6 ±.10]
D408W	white	approx. 2.9 [12.8]	.055 ±.002 [1.400 ±.05]	.94 ±.004 [23.9 ±.10]

- ▶ plastic housing and cover
- ▶ steel zinc plated yoke plates

Snap-in Magnetic Catch

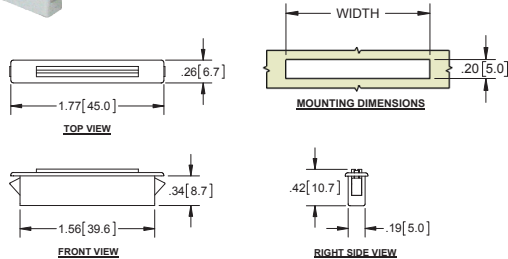

Part Number	Color	Holding Force lbf [N]	Panel Thickness	Cut-out Width
D403	white	approx. 6.2 [27.5]	.031 [.79]	1.571 [39.90]
		approx. 6.2 [27.5]	.039 [.99]	1.594 [40.50]

- ▶ plastic housing and cover
- ▶ steel zinc plated yoke plates

Snap-in Magnetic Catch

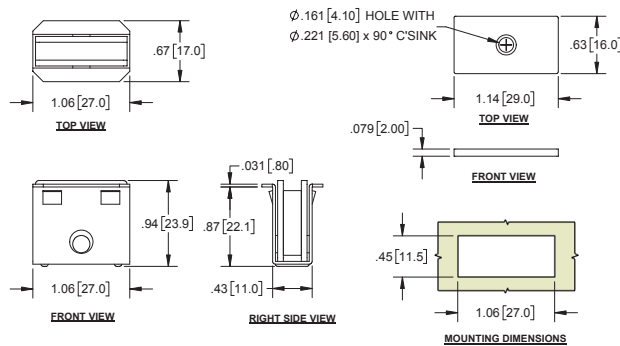
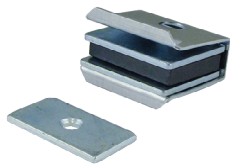

Part Number	Holding Force lbf [N]
D416	approx. 6.6 [29.4]

- ▶ aluminum, mill finish housing
- ▶ steel, zinc plated keeper and yoke plates
- ▶ snaps into a 1mm thick panel

Sealed Snap-in Magnetic Catches

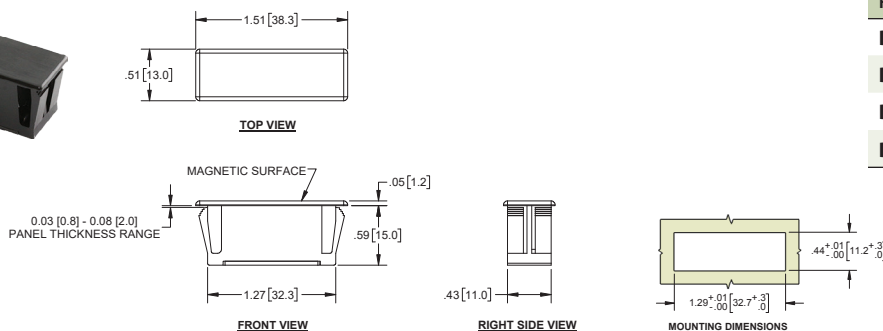

Part Number	Finish	Holding Force
D436BK	black	approx. 6.7 [30]
D436W	white	approx. 6.7 [30]
D436BK-01	black	approx. 4.0 [18]
D436W-01	white	approx. 4.0 [18]