

TOP VIEW

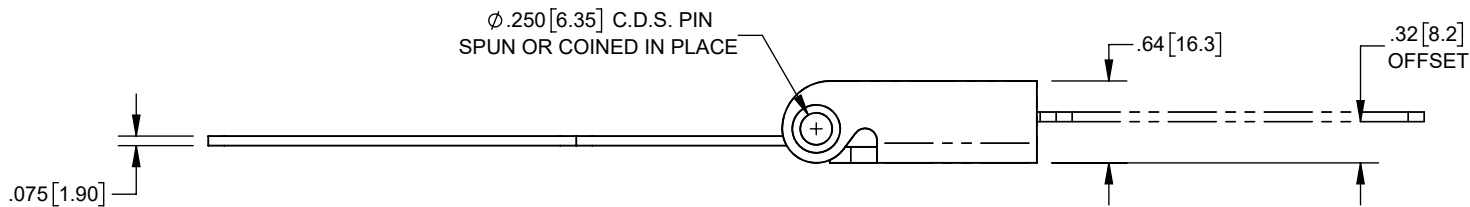
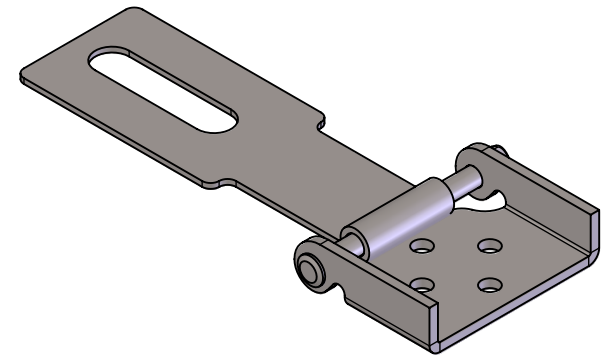

FRONT VIEW

NOTE:
DIMENSIONS IN BRACKETS ARE IN METRIC.

<p>SIERRA PACIFIC ENGINEERING AND PRODUCTS © SPEP.COM</p>		UNSPECIFIED TOLERANCES		MATERIAL: STEEL	PART NUMBER: 2830ZN
		ANGLES: ±3°		FINISH: BLUE ZINC PLATED	DESCRIPTION:
CONFIDENTIAL PROPRIETARY INFORMATION	PLOT DATE: 4/21/2023	INCHES	MM	UNITS: INCHES	<p>STEEL SWAGED HASP ASSEMBLY</p>
<p>This document contains information that is the confidential and proprietary property of SPEP and may not be copied, published, or disclosed to others, or used for any purpose other than review, without the express written authorization of an authorized officer of SPEP. This document must be kept only in SPEP's confidential files when not in use.</p>		.XX ±.030	.X ±.76	SCALE: 1:1.5	
		.XXX ±.015	.XX ±.38	THIRD ANGLE PROJECTION	
		.XXXX ±.005	.XXX ±.13	WEIGHT: 0.392 SIZE: A SHEET 1 OF 1	
				DWG. NO. 16051-2830ZN	