

**FRONT VIEW**

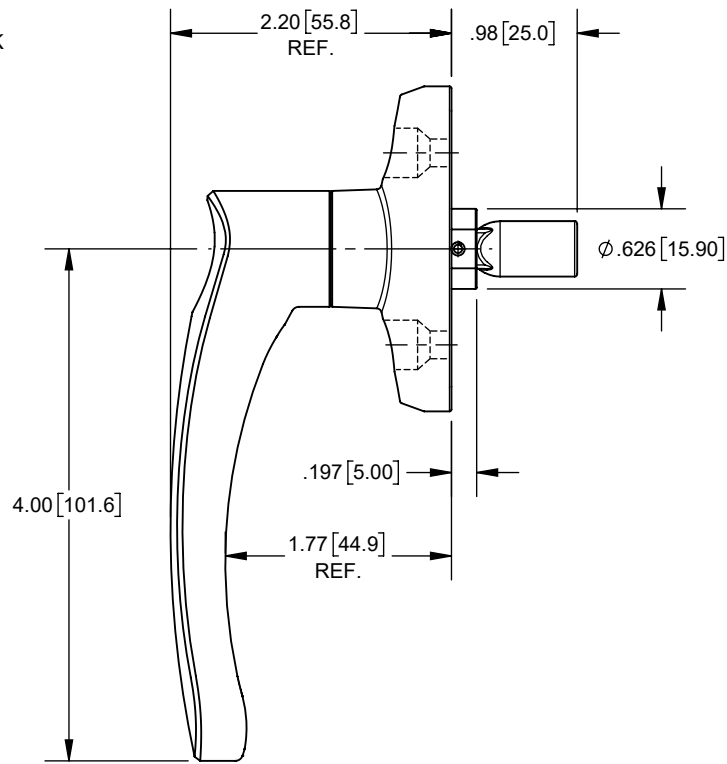

**RIGHT SIDE VIEW**

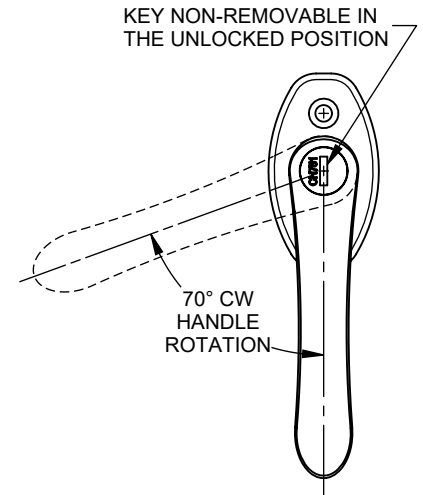

**HANDLE ROTATION**

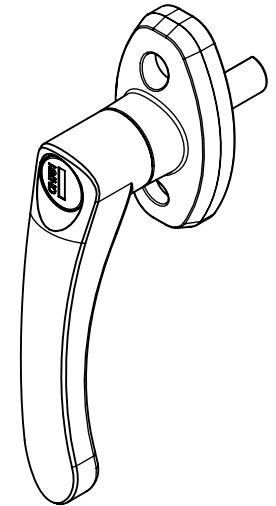

**NOTE:**

DIMENSIONS IN BRACKETS ARE IN METRIC.

<p align="center"><b>SIERRA PACIFIC</b> ENGINEERING AND PRODUCTS © SPEP.COM</p>		UNSPECIFIED TOLERANCES		MATERIAL: DIE CAST ZINC	PART NUMBER: <b>3151-110</b>		
		ANGLES: ±3°		FINISH: CHROME PLATED	DESCRIPTION:		
CONFIDENTIAL PROPRIETARY INFORMATION	PLOT DATE: 4/21/2023	INCHES	MM	UNITS: INCHES	<p align="center"><b>FRONT-MOUNT L-HANDLE WITH KEY REMOVABLE IN THE LOCKED POSITION ONLY</b></p>		
<p>This document contains information that is the confidential and proprietary property of SPEP and may not be copied, published, or disclosed to others, or used for any purpose other than review, without the express written authorization of an authorized officer of SPEP. This document must be kept only in SPEP's confidential files when not in use.</p>		X	±.060	X		±1.5	
		.XX	±.030	.X		±.76	
		.XXX	±.015	.XX		±.38	WEIGHT: 0.638
		.XXXX	±.005	.XXX	±.13	DWG. NO. <b>22046-3151-110</b>	